

GLB 80



MADE IN GERMANY

Deutsch: Reinigung und Pflege durch Abwischen mit einem feuchten Tuch und nachwischen mit einem trockenen Tuch.

Bitte entfernen Sie während des Aufbauvorgangs die Etiketten der Montagebeschriftung.

English: Cleaning and care by wiping with a damp cloth and wiping with a dry cloth. Please remove the labels of the assembly inscription during the assembly process.

Francais: Nettoyage et entretien en essuyant avec un chiffon humide et en essuyant avec un chiffon sec. Veuillez retirer les étiquettes de l'inscription de l'assemblage pendant le processus d'assemblage.

Espanol: Limpieza y cuidado pasando un paño húmedo y pasando un paño seco. Retire las etiquetas de la inscripción del ensamblaje durante el proceso de ensamblaje.

Italiano: Pulizia e cura strofinando con un panno umido e strofinando con un panno asciutto. Si prega di rimuovere le etichette della scritta di assemblaggio durante il processo di assemblaggio.

Deutsch: Vor der Montage ist die Wand unbedingt auf ausreichende Tragfähigkeit zu prüfen. Befestigungsmittel für die Wandmontage sind nicht beigegeben, da sie für die jeweilige Wandbeschaffenheit geeignet zu wählen sind. Wir empfehlen eine Beratung durch den Fachhandel oder die Montage durch eine fachkundige Person. Beachten Sie, dass im Befestigungsbereich keine Elektroinstallationszonen und keine Ver- und Entsorgungsleitungen vorhanden sein dürfen und dass die Wand im gesamten Bereich des Möbels plan ist.

English: Before installation, it is essential to check the wall for sufficient load-bearing capacity. Fasteners for wall mounting are not included, as they must be selected to suit the respective wall condition. We recommend that you seek advice from a specialist retailer or have it installed by a qualified person. Please note that there must be no electrical installation zones or supply and disposal lines in the fastening area and that the wall must be flat in the entire area of the unit.

Francais: Avant le montage, il faut impérativement vérifier que le mur présente une capacité de charge suffisante. Les moyens de fixation pour le montage mural ne sont pas fournis, car ils doivent être choisis en fonction de la nature du mur. Nous recommandons de demander conseil au commerce spécialisé ou de confier le montage à une personne compétente. Veillez à ce qu'il n'y ait pas de zones d'installation électrique ni de conduites d'alimentation et d'évacuation dans la zone de fixation et que le mur soit plan dans toute la zone du meuble.

Espanol: Antes de la instalación, es imprescindible comprobar que la pared tenga suficiente capacidad de carga. Las fijaciones para el montaje en pared no están incluidas, ya que deben seleccionarse en función del estado de la pared. Le recomendamos que se asesore en un comercio especializado o que encargue la instalación a una persona cualificada. Tenga en cuenta que no debe haber zonas de instalación eléctrica ni conductos de alimentación y evacuación en la zona de fijación y que la pared debe ser plana en toda la zona del aparato.

Italiano: Prima dell'installazione, è essenziale verificare che la parete abbia una capacità di carico sufficiente. Gli elementi di fissaggio per il montaggio a parete non sono inclusi, poiché devono essere scelti in base alle condizioni della parete. Si consiglia di rivolgersi a un rivenditore specializzato o di far installare l'apparecchio da una persona qualificata. Si ricorda che nell'area di fissaggio non devono essere presenti zone di installazione elettrica o linee di alimentazione e smaltimento e che la parete deve essere piana in tutta l'area dell'unità.

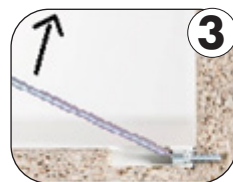
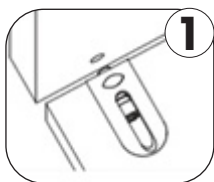
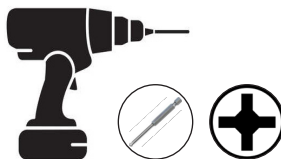
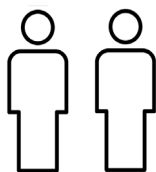



Length: 552.00
Width: 100.00

Schwarze Platten
Montage **18**

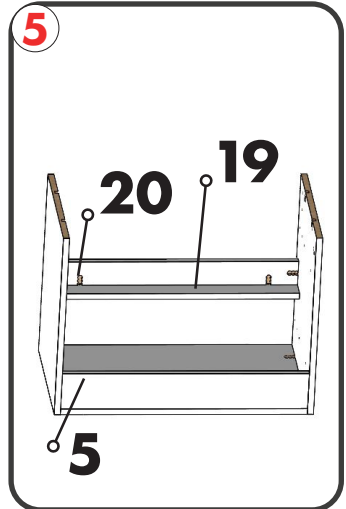
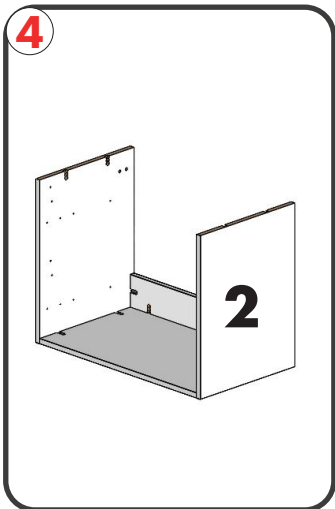
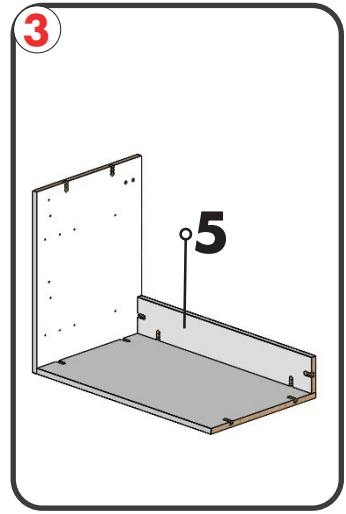
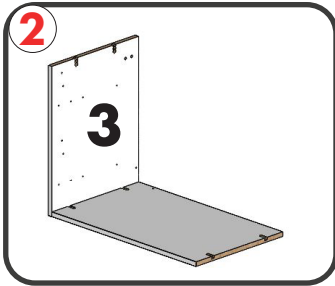
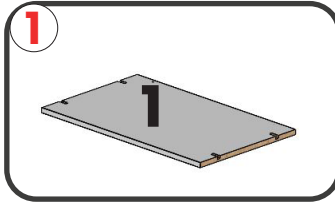
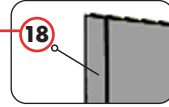



030 837 98 322

kontakt@garlivo.com

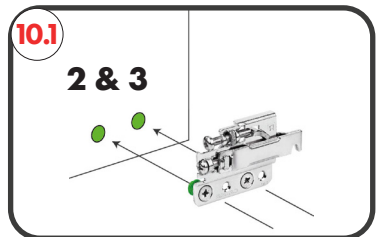
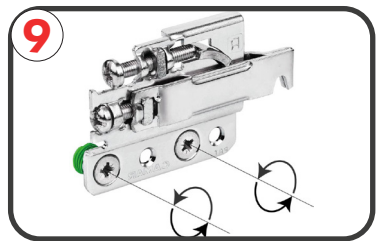
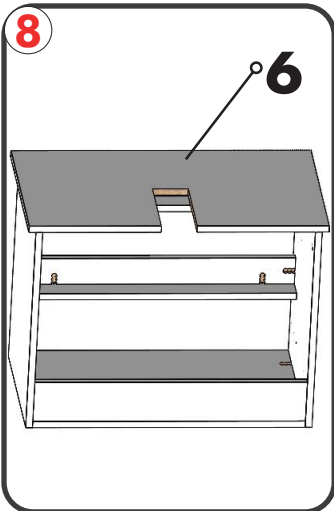
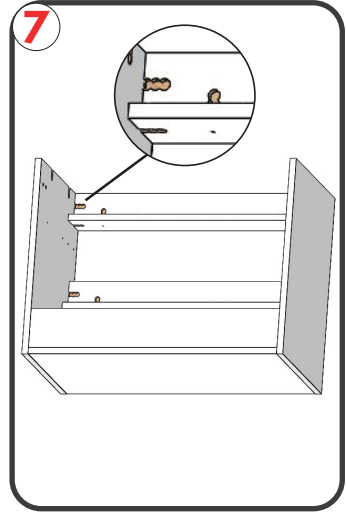
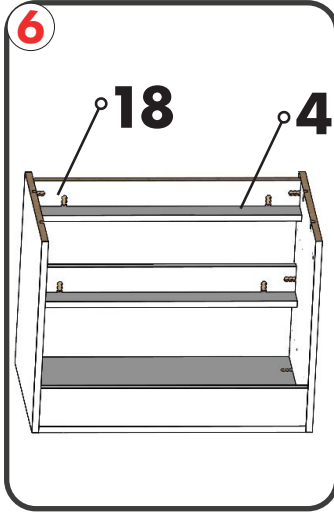



Length: 552.00
Width: 100.00

Schwarze Platten
Montage **18**

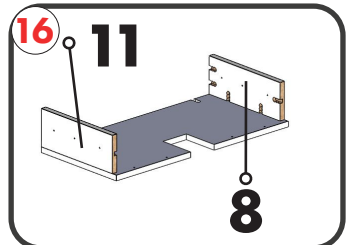
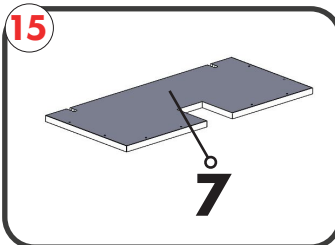
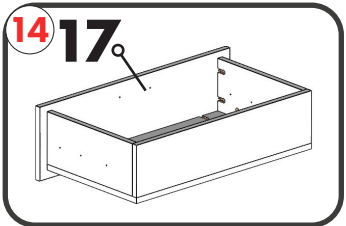
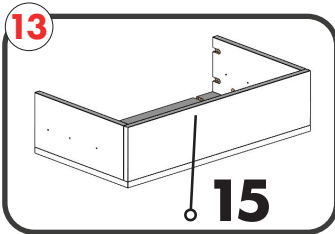
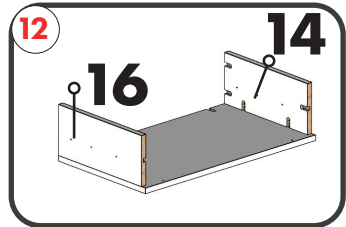
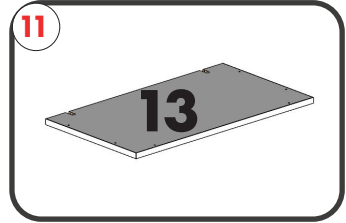
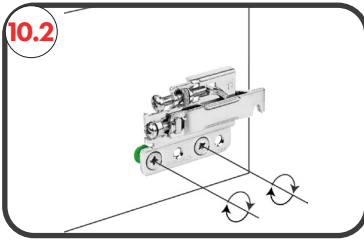
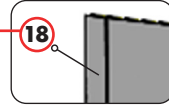



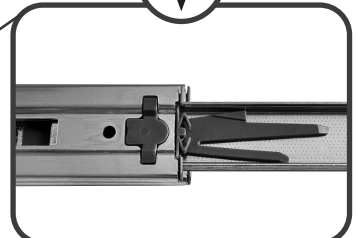
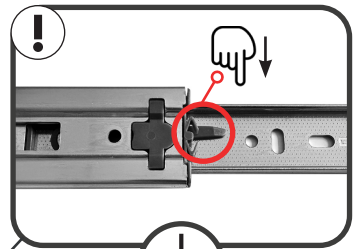
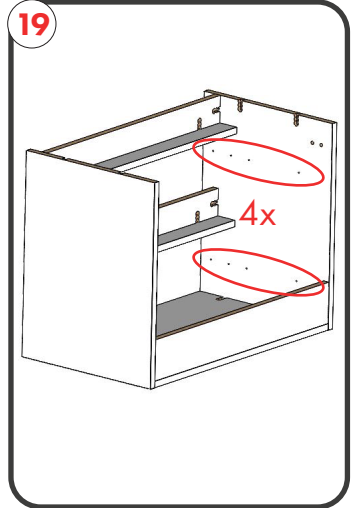
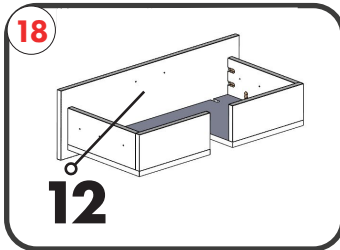
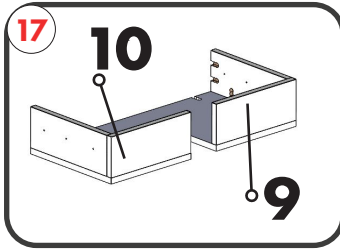

030 837 98 322

kontakt@garlivo.com

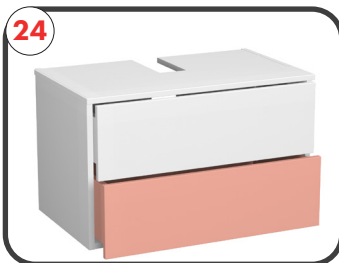
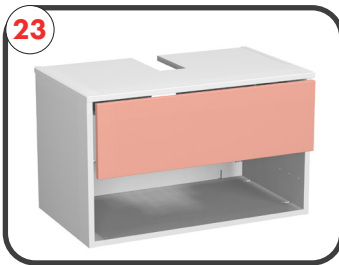
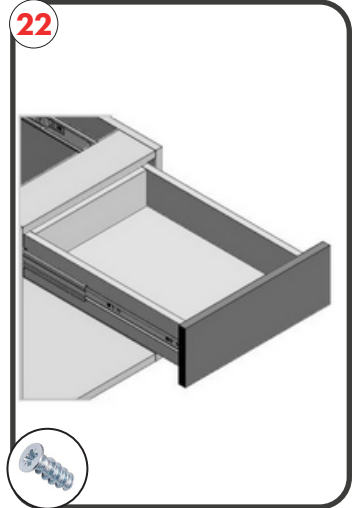
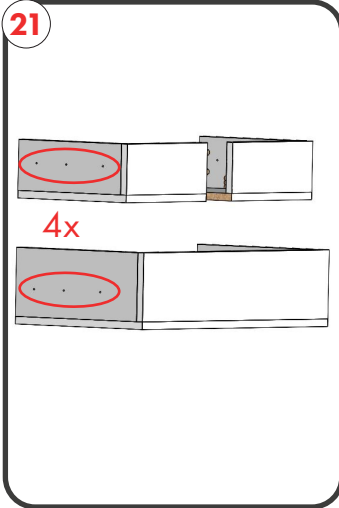



Für die Nachbestellung benötigen wir die abgebildete Nummer auf dem Brett
For reordering we need the number shown on the board

GARLIVO	0002536
Length: 552.00 Width: 100.00	Schwarze Platten Montage - 18
	

Garlivo GmbH
Lilienthalstraße 10, 15344 Strausberg,
E-Mail: kontakt@garlivo.com
Telefon: 030 837 98322
Eingetragen bei Amtsgericht Frankfurt (Oder), HRB 20163 FF
WEEE-Nr DE 39111042